

DASH NO.	APPLICATION		REVISIONS			
	NEXT ASSY.	USED ON	LTR	DESCRIPTION	DATE	APPR
			B	.281 WAS .390	9/18/96	

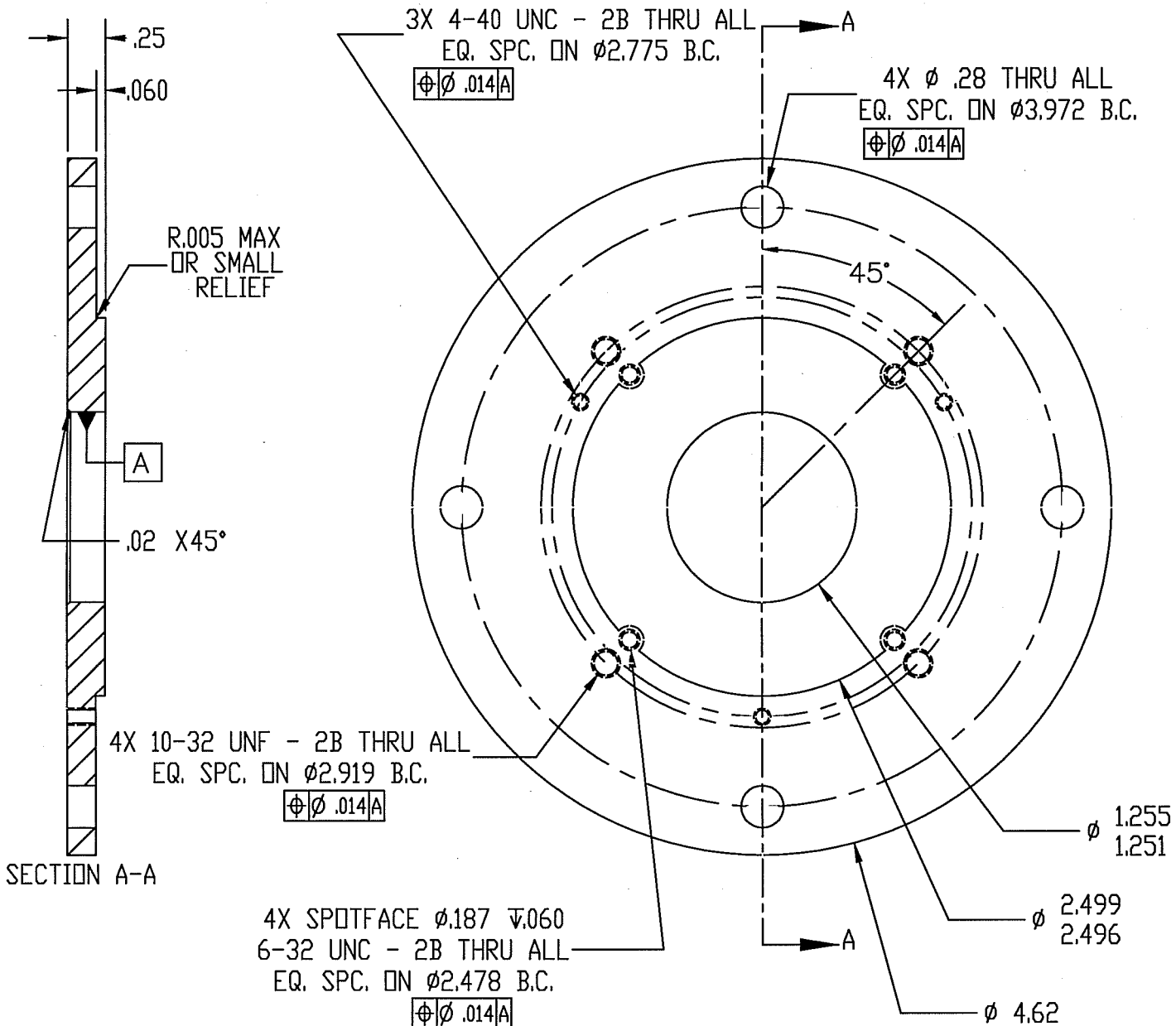

Dim's in [] are millimeters and tolerances are:
.x = $\pm .25$.xx = $\pm .127$.xxx = $\pm .063$

USED WITH H25D, H25E W/CLEATS, OR H20D

UNLESS OTHERWISE SPECIFIED DIMENSIONS ARE IN INCHES APPLY AFTER FINISH TOLERANCES ON XX $\pm .01$ XXX $\pm .005$ ANGLES $\pm 0^\circ 30'$ REMOVE BURRS AND BREAK ALL SHARP EDGES .010 MAX ALL DIA. TO BE $\nabla .010$	DRAWN	DM	DATE
	CHECK	<i>MFB</i>	
	ENGR		
	APPR	<i>AB</i>	9/21/96
	MATERIAL	ALLOY 6061-T6	
	FINISH		

BEI INDUSTRIAL ENCODER DIVISION
BEI TECHNOLOGIES, INC.

TITLE			
ADAPTOR, H25D/E TO 5PY			
SIZE	FSCM NO.	DWG NO.	REV.
A	1RB90	924-38228-001	B
SCALE	1:1	FILE	SHEET 1 of 1

THIS DOCUMENT CONTAINS PROPRIETARY INFORMATION OF
BEI TECHNOLOGIES, INC. ANY REPRODUCTION, USE OR DISCLOSURE
OF THIS DOCUMENT WITHOUT WRITTEN CONSENT OF
BEI TECHNOLOGIES, INC. IS EXPRESSLY PROHIBITED.